



SPECIAL FEATURES

Economical Version
General Purpose Application

APPLICATION

Low Pressure Draft Measurement, Food & Beverages, Pharmaceutical, Breweries, Clean Air, Gaseous, Low Viscous Liquid & Non Corrosive Media that will not obstruct the pressure system.

STANDARD VERSION

Nominal Size: 63mm

Model: CC9 - 00 - A Bottom Connection / CC9 - 00 - D - Center Back Connection

Accuracy class	1.6%
Case & Bezel	Steel, Powder Coated/painted (push fit type)
Socket	Copper Alloy
Capsule System	Copper Alloy
Movement	Copper Alloy
Window push -in	Plexiglas
Thread	1/4" BSP
Dial	Aluminum, black graduation on white back ground
Pointer	Black colored, fixed
Max. Process Temperature	45°C
Range in mbar or equivalent	0 – 25 0 – 600

OPTIONS

CC9 - 00 - C Back Flange for wall mounting / CC9 - 00 - E Front Flange for panel mounting

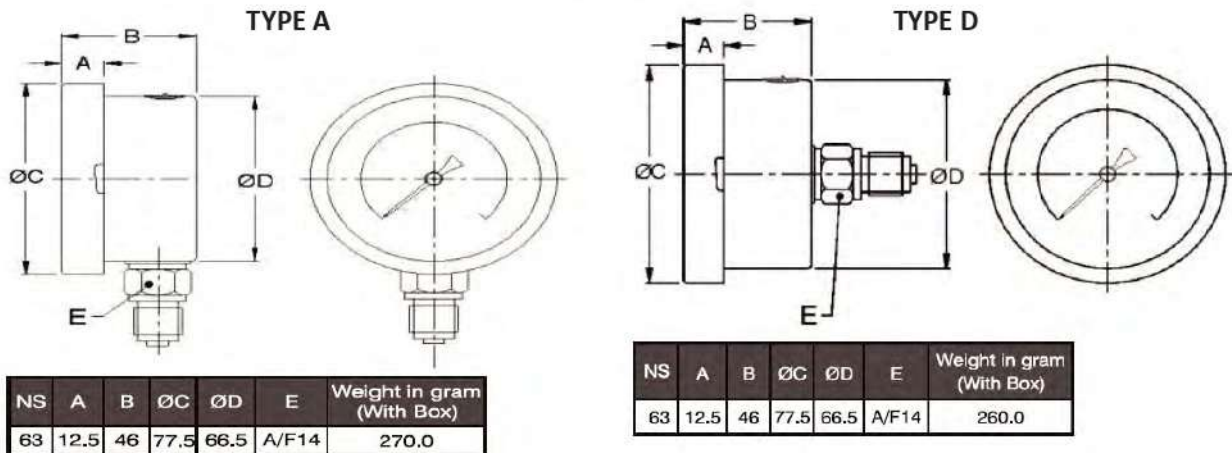

Notes : • Drawings are not to scale. • All Dimensions are in mm. • NS = Nominal Size.